

SHEETFOLDER AMFOLD

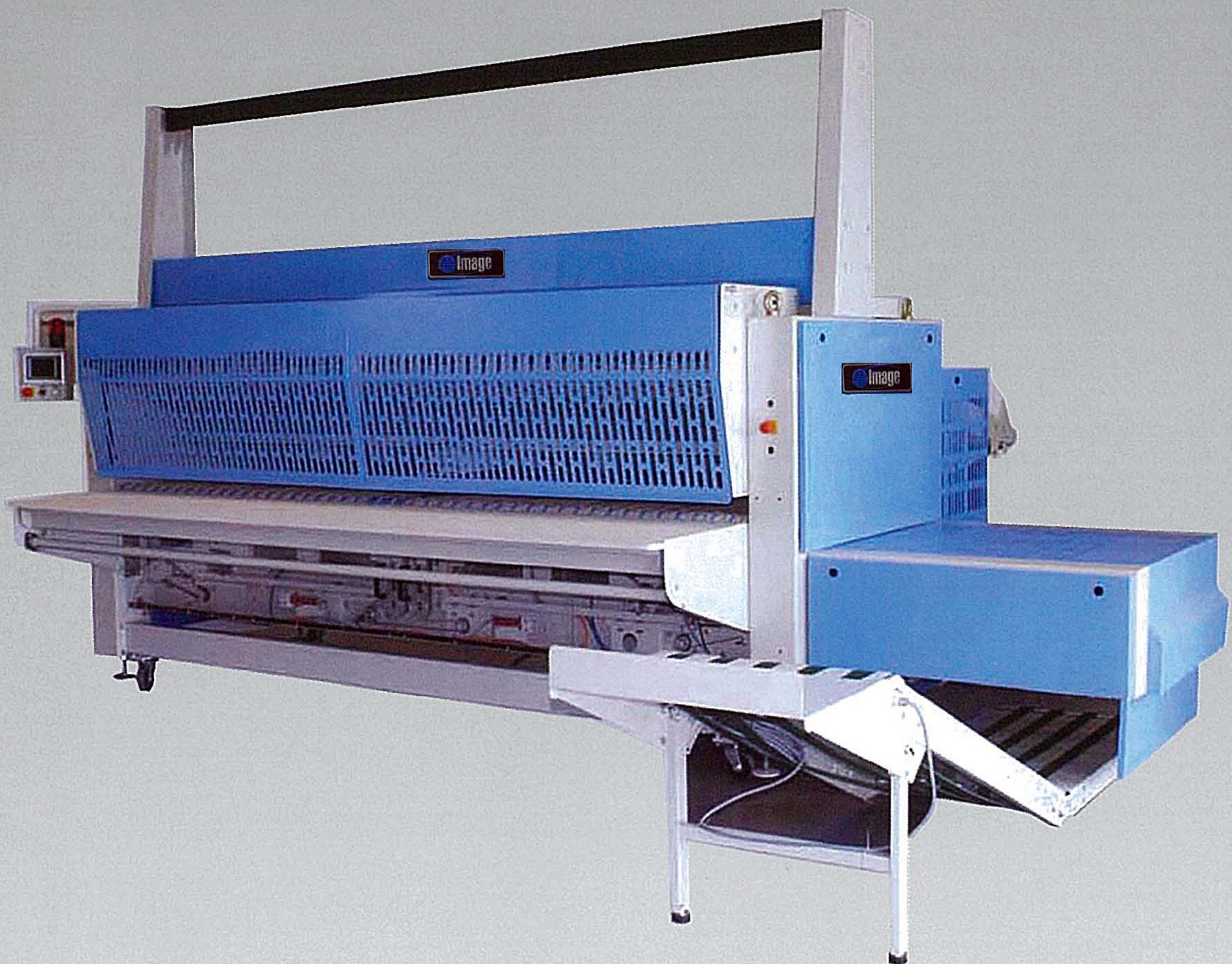

Amfold-P with Amstack-D
(Amscan is optional)

Up to 1500 pieces/hour
Compact
Touch screen panel
All cross folds timing belt driven
Easy access

Specifications

Standard Features

- 2 to 3 lateral folds
- Program control from feeder
- Photocells face down without mirror
- Several cross fold combinations available
- Standard Ethernet connection
- USB stick connection for back up of setting

E - Economic sheet folder for sheets

P - Standard sheet folder, all crossfolds with knife folds

Q - Quality sheet folder, with various crossfolding, various crossfold speed, all knife crossfolds

Technical information

Specifications

Electrical

- Voltage : 3x 400V+N+PE / 50Hz
- Power : 1,25-2kW, Fuses 10A

Pneumatic

- Pressure : 6-10 Bar
- Consumption : 20-30 KNL/1000 sheets
- Connection : 3/8" (1/2" tube)

Miscellaneous

- Noise level : 75dBA
- Speed : 8 up to 55 m/min

Production Materials Sheets (with crossfolds)

- Sheets, table linen, draw sheets, etc.
- Max. size 1 lane : 3,3m x working width
- Min. size 1 lane : 0,9m x 0,9m

Small pieces

- Max. size multilane : 1,3m x lane width
- Min. size multilane : 0,4 x 0,25m

*are depending on configuration

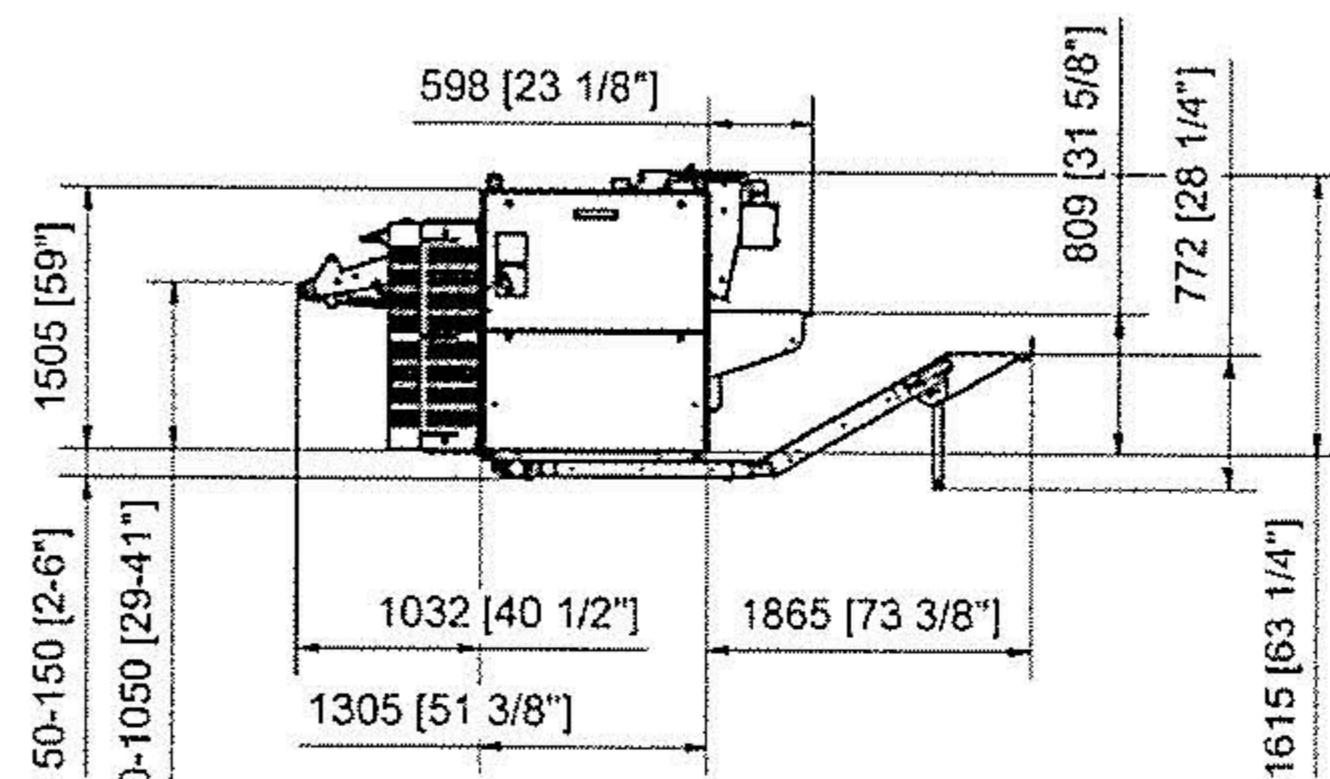
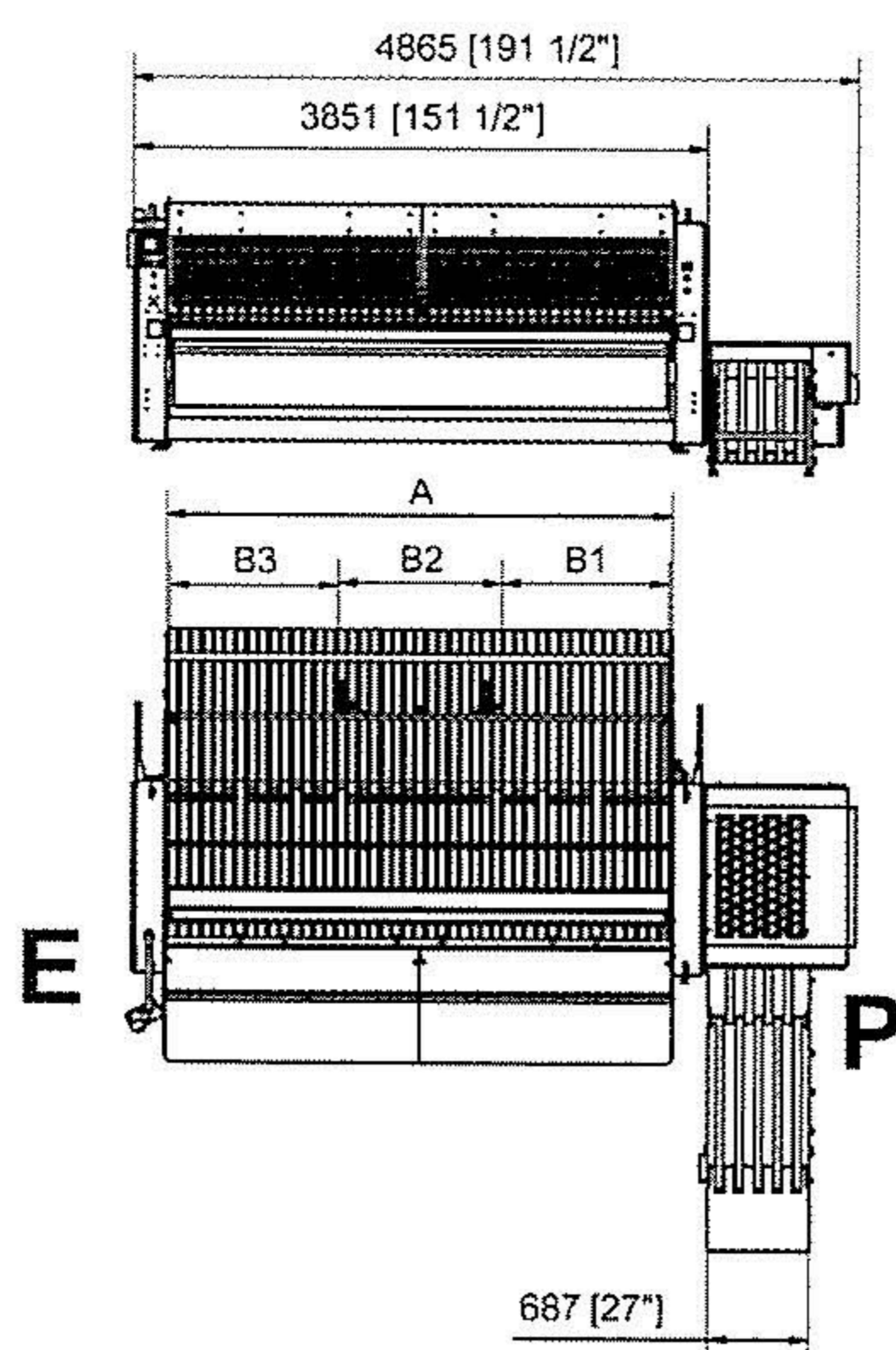

Working width	A	B1	B2	B3	B4
2700 [105 1/4"]	2800 [110 1/4"]	900 [35 1/2"]	900 [35 1/2"]	900 [35 1/2"]	
3000 [118 1/8"]	3100 [122"]	975 [38 3/8"]	1050 [41 3/8"]	975 [38 3/8"]	
3200 [126"]	3250 [128"]	1050 [41 3/8"]	1050 [41 3/8"]	1050 [41 3/8"]	
3300 [130"]	3400 [133 7/8"]	1125 [44 1/4"]	1050 [41 3/8"]	1125 [44 1/4"]	
2700 [105 1/4"]	2800 [110 1/4"]	675 [26 1/2"]	675 [26 1/2"]	675 [26 1/2"]	675 [26 1/2"]
3000 [118 1/8"]	3100 [122"]	750 [29 1/2"]	750 [29 1/2"]	750 [29 1/2"]	750 [29 1/2"]
3200 [126"]	3250 [128"]	825 [32 1/2"]	750 [29 1/2"]	750 [29 1/2"]	825 [32 1/2"]
3300 [130"]	3400 [133 7/8"]	825 [32 1/2"]	825 [32 1/2"]	825 [32 1/2"]	825 [32 1/2"]

Specification and Design subject to change without notice
Additional options : Consult factory or distributor

Distributed by : K.H.T Central Supply Co.,Ltd. Bangkok, Thailand.

Phone: +66(0)2249-1026 Fax: +66(0)2249-5114

www.khtcs.com Email: sales@khtcs.com