

X-SERIES



CONTINUOUS BATCH WASHER

X-Power 40/60/90

Based on our long quality tradition the continuous batch washer of the X-Power series is extremely rigid and reliable. The machine design includes all the advantages of a bottom transfer machine and a double drum execution. Different machine sizes for batch sizes of 40kg to 100kg are available. They differ in the length and the diameter. Stainless steel inner and outer drums and piping are the standard. The total lowmaintenance concept allow the economic work with his machines. The highest hygienically standards were full- filled. Special executions and optional equipment is available on request.

Our batch washer is equipped in the standard with a high efficient washing technology. After the cycle time the linen is pushed and shifted to the next compartment with out lifting it. Due to this bottom transfer technology the linen is transported with safety and mild.

A ready to use machine even in the standard execution underlines the complete concept idea. Universal and flexible with various added options and custom made solutions are further possibilities. Always focused one the customer s needs and requests we can offer various machine sizes with different washing capacities. In combination with our other machines a complete washing line can be established.



- Inner and outer drum are concept with extreme small clearance and fulfill the highest hygienic standards. Three connections for chemical to each compartment and 8 free programmable dosing contacts allow various washing procedures.
- The washing procedure is based on the water flow into the tunnel. A combination of water flow in and against linen transport direction create a high efficient filtering and streaming. Adjustable water height and overflow pipes are also included.
- Newest water recycling and filtering technologies work together in our machines. Extreme low water consumption due to large water recycling tanks which is standard.
- Intelligent control systems are programmed to the future aspects of washing technology.
- Easy to understand control and programming software make it simple to adjust the machine for every washing process and all program parameter. The user terminal has a touch screen monitor for visualizing all necessary information in graphic mode from the high quality PLC system. Pending angle, turning speed, unloading speed and all data specifying a wash program can be programmed. Data reports and storage is also an optional feature.

IMAGE is produced by Accurate technologies in Thailand. High quality standards and qualified engineering guarantee for years of the high performance of our machines.

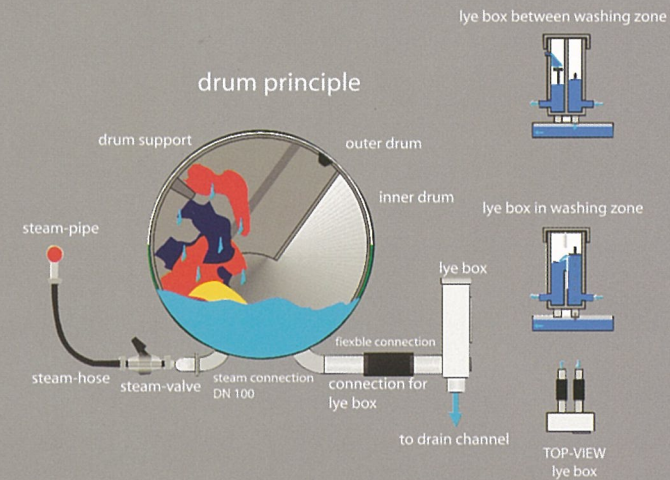
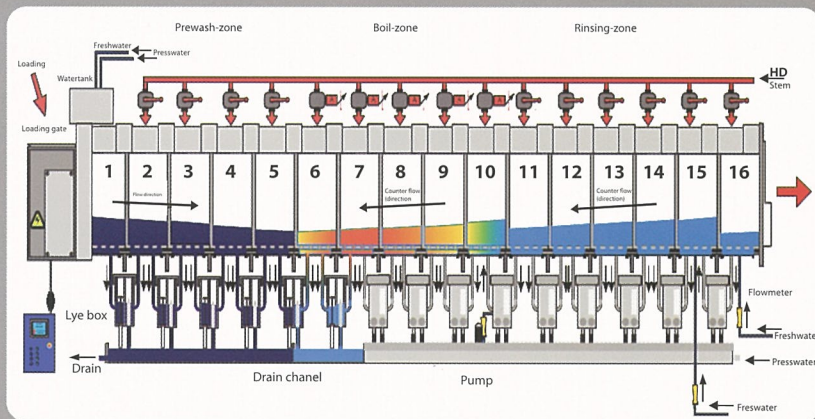

Options:

- Thermal insulation of drum
- Rapid drain device in lye box
- Data record and storage system
- Additional monitor
- Printer
- Media measurement devices
- pH probe and connection
- Additional dosage contacts
- Others features upon request

Standard Features :

- Stable design up to 21 compartments
- Drum and piping made of stainless steel
- Integrated water recovery tank
- Linen transfer on bottom
- Big size loading funnel
- Floating tank on top of the machine
- Low-Maintenance support of the drum
- PLC control with dialogue menu
- 50 Free adjustable washing programs
- Graphic LCD colour display (Touch screen)
- Integrated fault trouble shooter

X-Press 40/60/90

The Single Station dewatering press of the IMAGE PRESS type are performing a extreme rigid mechanical design and high reliability. Different sizes corresponding to the batch size from 40kg to 100kg are available. It varies in the height, the basket diameter and the equipped hydraulic. Left or right discharge direction is available besides the unloading in line. Customer made design like extension of the discharge unit or special voltages are possible on request.

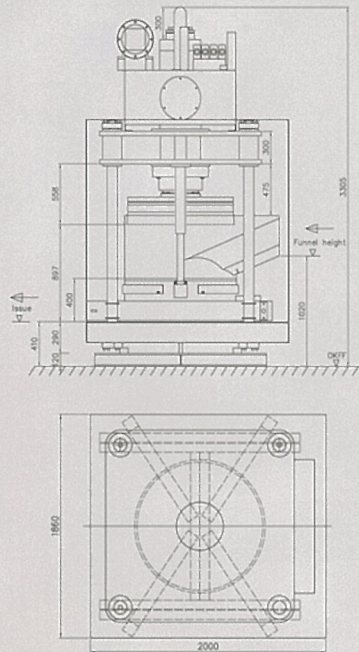

Standard Features :

- Stable design (10.000kg)
- Frame construction with clamped columns
- All parts in contact with linen are made of stainless steel
- Hydraulic unit with $p_{max}=310bar$
- Stainless steel covers
- Over sized natural rubber membrane
- Mechanical discharge pusher
- PLC control with text and graphic display
- PLC Menu and dialog programming
- Selectable pre-press sequence
- Four parametric pressure stages
- 15 adjustable pressure programmes
- Integrated alarm and fault message system

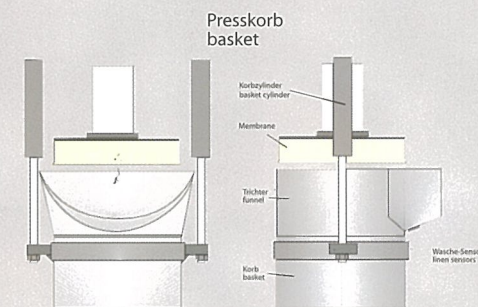
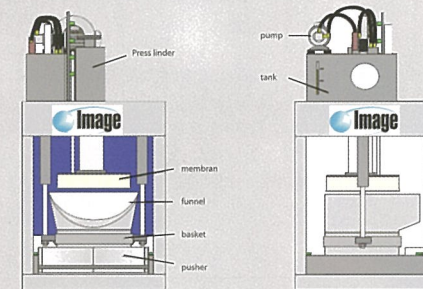

X-Controller

PLC controls and terminals can handle all different kinds of machineries and systems. PC controls with Touch Screen terminals handle the data input and visualization of all the system processes. High quality built in components guaranty the most effectivity.

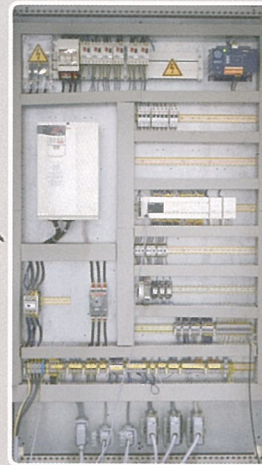

All IMAGE-controls have a proofed long life design
The controls are available for

- Loading conveyors
- Bg loading systems
- Tunnel washer
- Presses
- Shuttle conveyor
- Intermediate conveyor
- Common control units
- Dryer
- Unloading conveyor
- Washer extractors
- Complete washing systems
- Special machineries
- Data record and storage systems

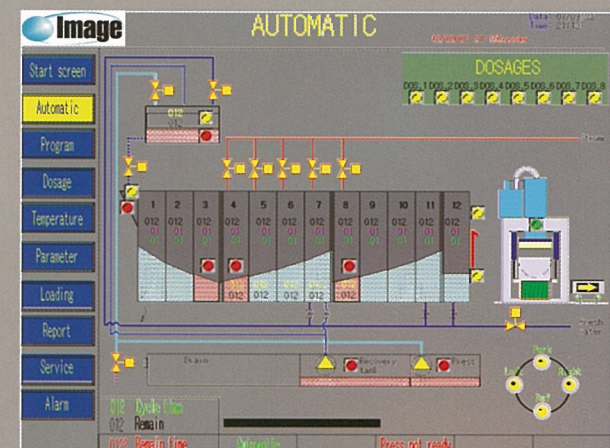
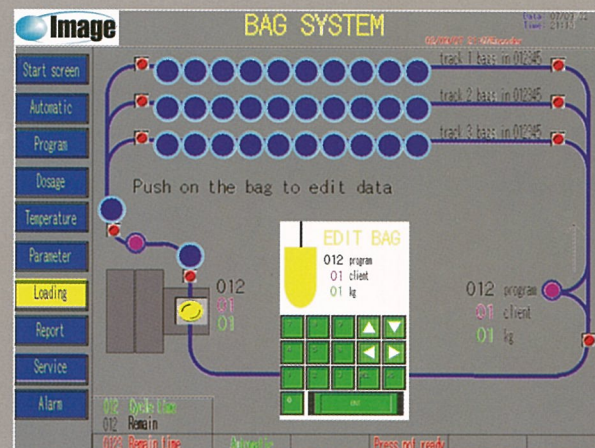
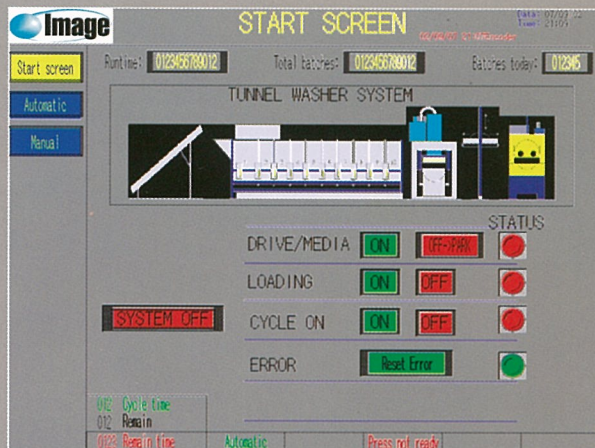

X-Dryer 75/100/150/200

Industrial High Productivity Dryers

Large Capacity › Flexibility › Built to Last › Protect your Investment

- **The X-Dryer Series is the perfect match for tunnel washing system operation.**

With capacity ranges from 100-kg up to 200-kg (225-450 pounds) makes our dryers range suitable for most tunnel washers capacities. Just ask and the dryer that suits the application can be built. Quality material and workmanship make the X-Dryer Series reliable and long lasting.

- **Microprocessor and Computer Control**

The X-Dryer Series control is capable of linking with the central control to work as a single system. The control monitors the temperatures, drying action and the performance with unsurpassed accuracy to ensure trouble free operation. The computer helps enhance safety in the laundry by verifying airflow and monitoring the temperature sensor and door.

- **Stainless Steel Basket**

The stainless steel 304 (18/8) cylinder is supported by four 11 inch diameter high temperature wheels. The wheels are adjustable keeping the cylinder in position at all times. The wheels on one side are connected to a shaft and a gear motor that drives the cylinder.

- **Lint Filter and Lint Compartment**

The lint filter is efficient and provides a good airflow that reduces energy consumption. The control monitors the lint filter and stops the machine should the lint screen become blocked. It is easily accessible from the side.

- **Air Flow Diagram**

The flow of the air through the basket is designed for optimum energy consumption.



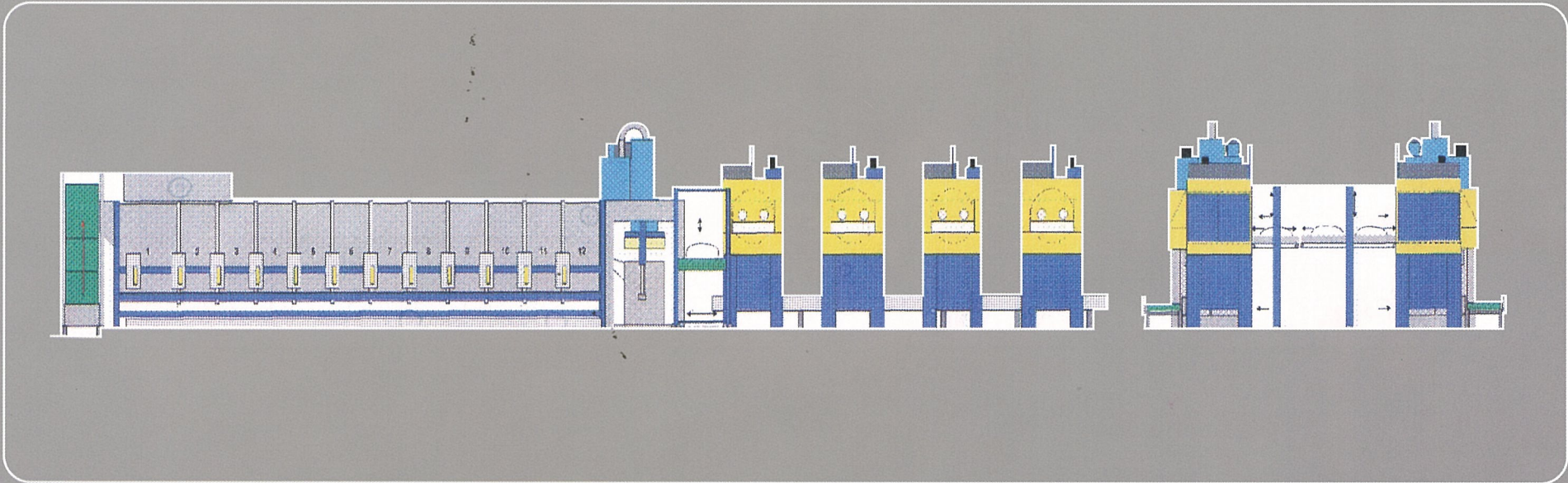

Heated Air Flow Circulation Diagram through the Steam Coil, Rotating Basket and extracted out by the suction Blows to the exhaust duct.

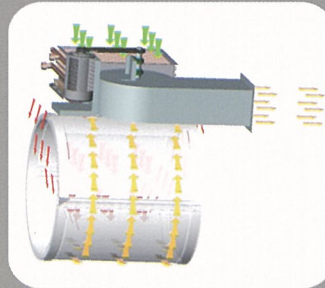
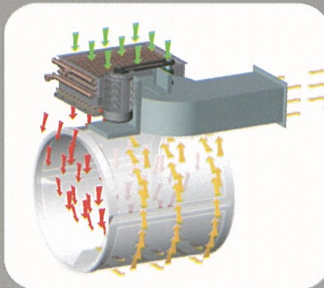
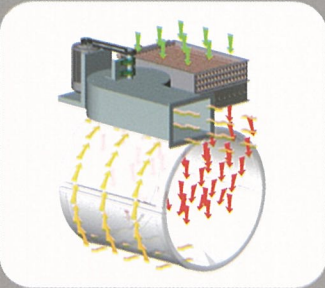
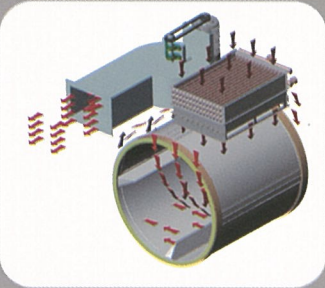

X-Transport

Monorail Bag Loading System

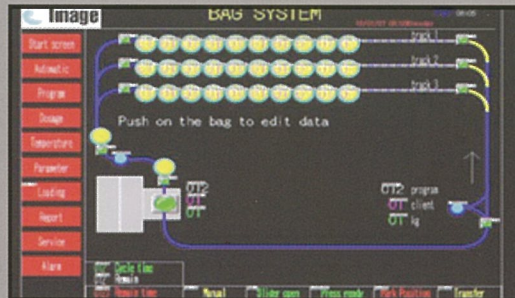
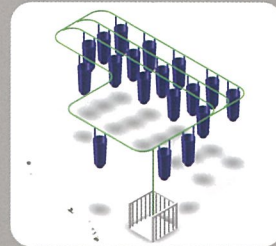
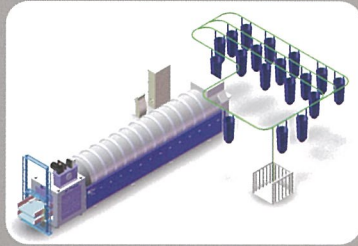

Conveyors

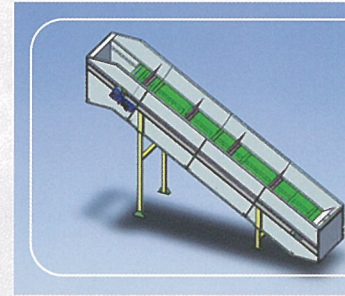

Loading Conveyor



Collecting Conveyor



Shuttles

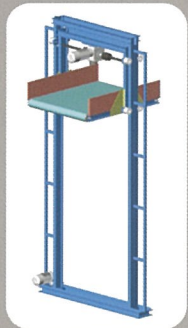

Single cake Shuttle

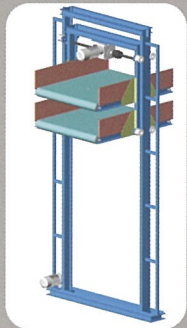

Dual cakes Shuttle

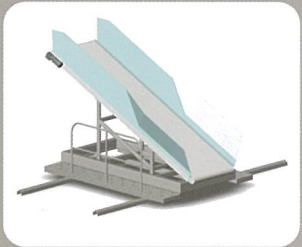

Single Shuttle

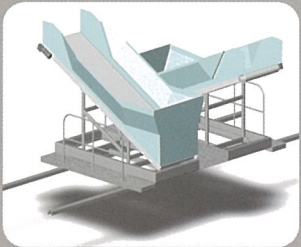

Dual Shuttle

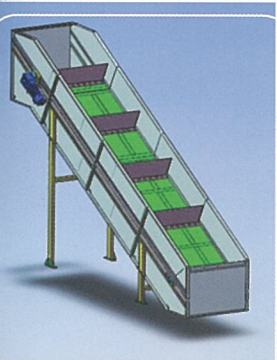

Reference

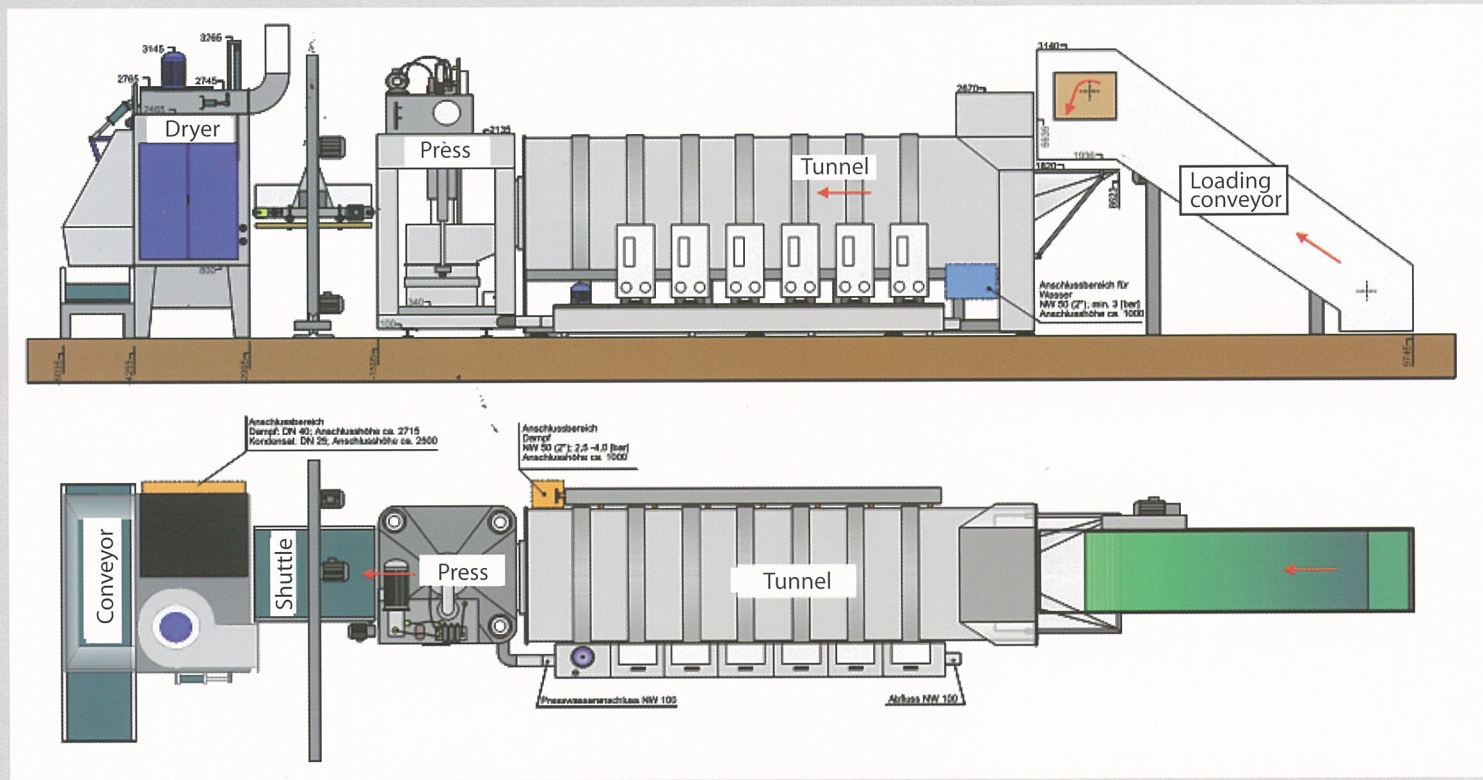

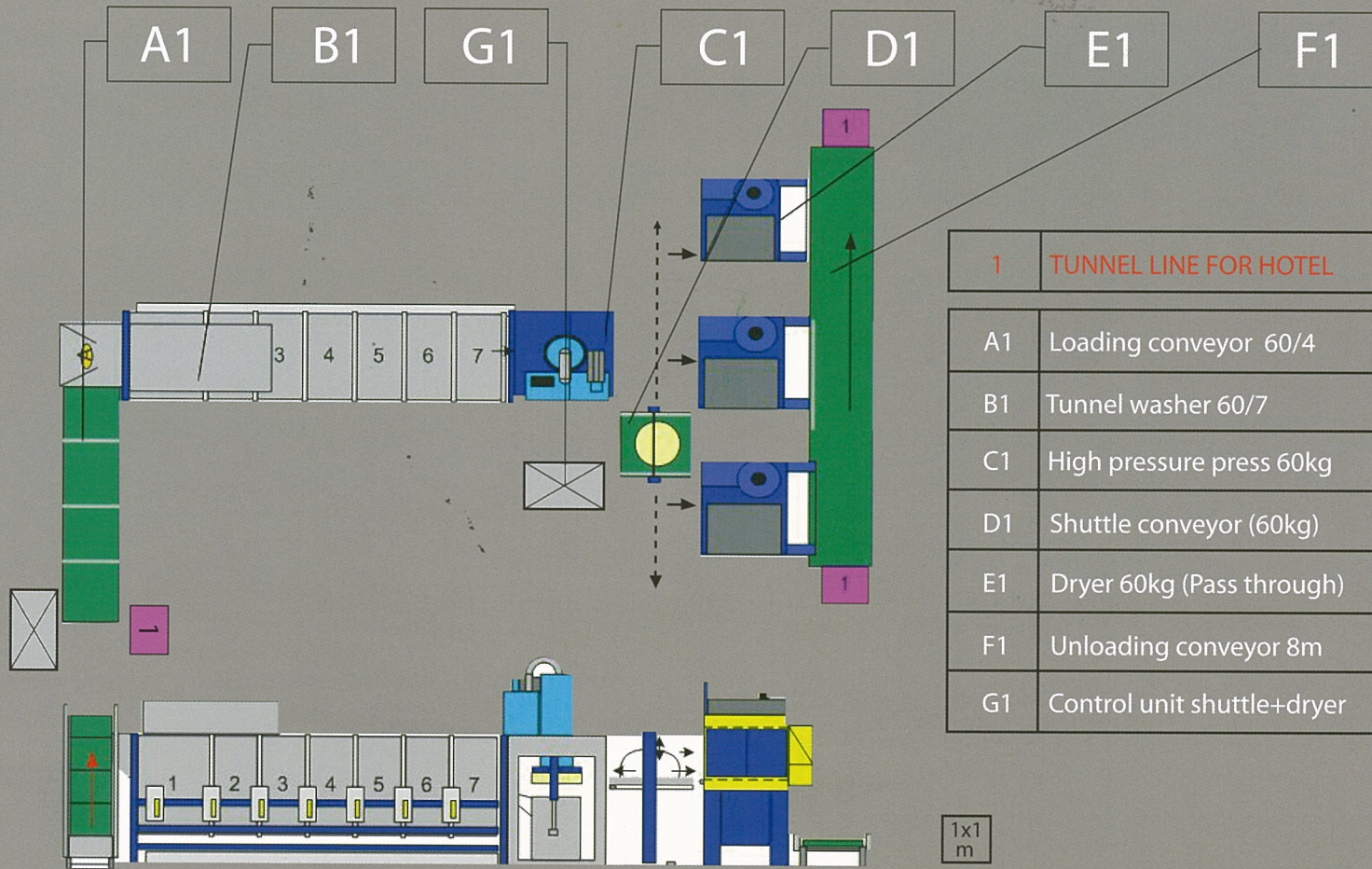

1	TUNNEL LINE FOR HOTEL
A1	Loading conveyor 60/4
B1	Tunnel washer 60/7
C1	High pressure press 60kg
D1	Shuttle conveyor (60kg)
E1	Dryer 60kg (Pass through)
F1	Unloading conveyor 8m
G1	Control unit shuttle+dryer



ACCURATE TECHNOLOGIES CO.,LTD

Bangkok, Thailand Phone : +66(0)2740-5511 (Auto) Fax : +66(0)2740-5522,2740-5533

www accuratethai.com Email : sales@accuratethai.com